

EXPERIMENTAL COMPARISON OF METHODS
OF DETERMINING THE THERMAL ACCOMMODATION COEFFICIENT

A. D. Terekhov and E. N. Frolova

UDC 533.722

An experimental comparison of two widely employed methods of determining accommodation coefficients is presented; these are the method of free molecular flow and the method of the temperature jump. The values of the coefficients which have to be introduced into the computing relationships of the temperature-jump method in order to obtain the true values of the accommodation coefficient are determined, this method being theoretically the less rigorous. Correction factors are determined for both monatomic and polyatomic gases.

Two methods are commonly employed at the present time in order to measure the thermal accommodation coefficient α : the method of free molecular flow and the temperature-jump method. The basic computing relationships for the two methods were given in [1].

A comparison between the experimental accommodation coefficients obtained by the two methods [2] shows that although the scatter characterizing the results of each method individually is very considerable, it is nevertheless smaller than the difference between the values of α obtained by the two different methods (for the same surface and the same gas). This poor agreement between the results cast serious doubt on the adequacy of the values of α obtained by the method of low pressures and the temperature-drop method, since it was a priori uncertain whether this difference had a good theoretical basis or whether it resulted from differences between the conditions of determination.

This problem has in effect only been examined theoretically by two authors, Thomas and Golike [2], who attempted a comparison between the methods in such a way as to ensure that, within the limitations imposed by the methods themselves (i.e., their difference in pressure), the experimental procedure and the conditions of the experiments should be kept constant. The results failed to provide any adequate answer to the question under discussion, and according to the authors themselves could only be considered as a further indication of the fact that the accommodation coefficients might vary with pressure due to the high-pressure adsorption of gas on the surface.

In its classical form [1] the temperature-jump method is not based on a very rigorous theory. Waylander [3] tried to construct an exact theory of the temperature jump for a rarefied monatomic gas on the basis of a solution of the Boltzmann equation for the molecular distribution function. The following expression was obtained for the temperature jump:

$$\Delta T = \frac{75\pi}{128} \cdot \frac{2 - Ka}{a} l \left(\frac{dT}{dx} \right)_n \quad (1)$$

which agrees with the generally accepted expression [1], apart from the coefficient K (l is the free path of the gas molecules). In Eq. (1) ΔT is the temperature jump, K is the correction factor for the temperature-jump method, $(dT/dx)_n$ is the temperature gradient along the normal to the surface.

For monatomic gases Waylander calculated $K = 0.827$. It should be noted that, owing to the complexity of the mathematical calculations of the collision integral in the Boltzmann equation, it is extremely difficult

Leningrad. Translated from Zhurnal Prikladnoi Mekhaniki i Tekhnicheskoi Fiziki, No. 4, pp. 173-176, July-August, 1972. Original article submitted August 30, 1971.

© 1974 Consultants Bureau, a division of Plenum Publishing Corporation, 227 West 17th Street, New York, N. Y. 10011. No part of this publication may be reproduced, stored in a retrieval system, or transmitted, in any form or by any means, electronic, mechanical, photocopying, microfilming, recording or otherwise, without written permission of the publisher. A copy of this article is available from the publisher for \$15.00.

TABLE 1

Pairs of tubes	Class of finish	Length of tubes, mm	Outer diameter, mm	Inner diameter, mm	Gap, mm
1 outer inner	8	180.0 121.5	33.50	33.99	0.245
2 outer inner	12	179.8 120.9	33.42	34.15	0.365
3 outer inner	8	179.8 121.6	36.94	39.71	1.390
4 outer inner	8	179.8 121.0	35.91	39.72	1.905
5 outer inner	8	180.0 121.1	33.94	39.75	2.900
6 outer inner	8	179.9 120.8	34.96	39.69	3.866
7 outer inner	12	180.3 121.0	31.48	40.20	4.358

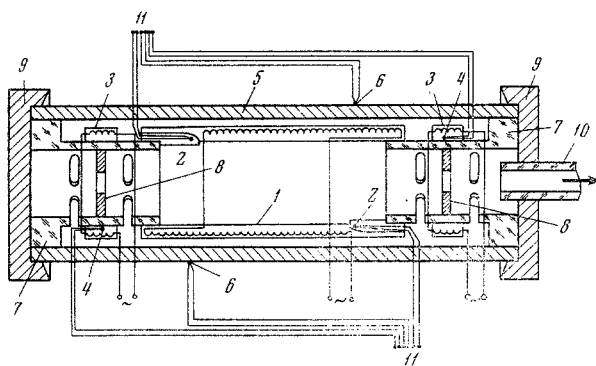

Fig. 1

between which a temperature difference ($T_1 - T_2$) of the order of 5° was maintained. (Here T_1 , T_2 are the temperatures of the outer surface of the inner tube and the inner surface of the outer tube, respectively.) The experimental temperature level was $\sim 290^\circ\text{K}$. The gap was filled with the gas under test. The diameters of the cylinders were chosen so as to satisfy the condition that the ratio of the gap width to the radius should be $\Delta/r < 0.1$. This reduced the problem to the case of heat transfer between two infinite plane surfaces. As material for the cylinders we used chromium-nickel steel of the 1Kh18N10T type.

The inner cylinder was heated to T_1 . The power of the main electric heater (a Nichrome spiral), determined from its voltage and resistance, was in general expended in transferring heat to the gas in the gap between the coaxial cylinders, in thermal radiation from the surface of the inner cylinder, and in thermal losses through the points at which the ends of the cylinders were sealed. The construction of the cylinders used in the experiments incorporated guard rings at the ends, with guard heaters in them; these were provided to compensate the outflow of heat at the ends and ensure uniformity of the temperature field along the generators of the inner cylinder.

The apparatus is illustrated in Fig. 1, in which 1 and 5 are the coaxial cylinders under consideration; 2, 4, and 6 are thermocouples; 3 are the guard rings; 7 are Ftorlon (analogous to Teflon) stoppers; 8 are copper reflecting discs; 9 are the tops of the vacuum sealing of the tube; 10 is a vacuum line; and 11 are leads to the potentiometer.

The efficiency of the compensation arrangements could be judged from the readings of a system of thermocouples on the outer surface of this cylinder.

The cylinders were fixed relative to one another by means of Ftorlon 4V stoppers, this being a material of low thermal conductivity. Open cuts in the main body of the Ftorlon stoppers interrupted any possible heat losses at the ends. The axial flow of radiation was reflected by polished copper discs mounted in the stopper and held at the temperature of the guard rings. All these structural features reduced the

to calculate the value of K for polyatomic gases, and the only method of determining this at the present time is by experiment.

We thought it desirable to make an experimental verification of the agreement between the accommodation coefficients obtained by the method of the temperature drop and the method of low pressures under strictly identical conditions, and also to determine the value of K experimentally for both monatomic and polyatomic gases.

To this end we set up the following experiment. The accommodation coefficient was determined from the equations of the thermal flux transmitted through a small annular gap Δ between two coaxial cylinders,

TABLE 2

Gases	a'	a''	K
Helium	0.265	0.250	0.78
Neon	0.582	0.525	0.82
Argon	0.740	0.655	0.83
Xenon	0.990	0.830	0.81
Air	0.693	0.655	0.92
Carbon dioxide	0.763	0.705	0.89
Water vapor	0.530	0.560	1.10

outflow of heat at the ends to a minimum, while the guard heaters compensated any residual loss of heat.

The temperature T_2 of the outer cylinder is kept constant by placing the whole construction in a special chamber with a thermostating liquid passing through it, this being taken from a liquid thermostat furnished with a contact thermometer and a thermal relay. The temperature is measured with thermocouples sealed into the body of the outer cylinder.

The radiative contribution to the heat transfer is taken into account by analogous thermal measurements in vacuum with the same temperature difference, i.e., for the case in which the gas pressure in the gap is so low that its molecular heat conduction may be neglected by comparison with the radiation. The gas pressure in the gap was measured between $1.5 \cdot 10^{-1}$ and $5 \cdot 10^{-4}$ mm Hg by means of an absolute compression-type McLeod manometer, and at higher pressures by means of a differential oil manometer. During the measurements the pressure remained constant within the reading accuracy of the McLeod manometer, which was used repeatedly in order to check this constancy. On holding the whole system at the lowest pressures for a long period it was found that leakage and evaporation amounted to less than 10^{-3} mm Hg over a period of three days.

Altogether experiments were carried out with seven pairs of coaxial cylinders. Table 1 indicates the geometry of each pair. Special attention was paid to obtaining identical surfaces. Five pairs of cylinders were processed on a circular polishing machine to give a class 8 surface finish, and two were honed (inner surfaces) and superfinished (outer surfaces) to class 12. The results of the polishing operations were monitored by analyzing profile recordings taken from the test surfaces.

As test gases we chose: helium, neon, argon, xenon, carbon dioxide, air, and water vapor.

The gaps chosen for the tubes of the eighth and twelfth classes of surface finish enabled us to obtain Knudsen numbers varying by a factor of approximately 20 times for different pairs of tubes of the same class of finish at the pressure. In this way we created the right conditions for the free molecular flow (tubes with small gaps) and the temperature-jump method (tubes with large gaps) under exactly the same pressure, i.e., with completely identical conditions at the surface. It should be noted that the test surfaces necessarily held adsorbed films, since after the high-temperature heating associated with the machining operations the surface of the steel was adsorption-active, and no special efforts were made to remove these films in the experiments. Although the resultant data relating to the accommodation coefficients cannot be ascribed to a completely clean surface of the 1Kh18N10T steel, the constancy of the conditions (the identical pressures and surface properties) governing all pairs of cylinders with one particular class of finish means that we may validly compare the methods of determining the thermal accommodation coefficient to the desired accuracy.

A comparison of Eq. (1) with the generally accepted expression for the length of the temperature jump leads to the following relationship for the coefficient K :

$$K = 1 - \left(\frac{1}{a''} - \frac{1}{a'} \right)$$

Here a' and a'' are the effective values of the accommodation coefficients for the two surfaces, obtained by the method of low pressures and the temperature-jump method, respectively.

The results obtained for the coefficients a' and a'' and the coefficient K are shown in Table 2.

The experiments showed that the accommodation coefficients were independent of pressure over the whole range between $5 \cdot 10^{-4}$ and 10 mm Hg; for each of the gases we were therefore able to determine these coefficients by reference to a whole series of points, both under temperature-jump conditions and also in the free-molecular (low-pressure) mode, and this greatly reduced the measuring error. Careful analysis and a calculation of the errors showed that the experimental mean square error in determining the average accommodation coefficient by each of the procedures in question was no greater than 3%, while the calculated value was of the order 4-5%.

The fact that the accommodation coefficient was independent of pressure, in spite of the presence of the adsorbed film on the steel samples, may simply be regarded as a consequence of the stability of the film over the whole range of working pressure.

We see from Table 2 that the coefficient K for the monatomic gases (helium, argon, neon, and xenon) lay close to the value of $K = 0.83$ calculated by Waylander. We may thus say that for monatomic gases the experiment confirmed the necessity of introducing the coefficient $K = 0.83$ into the expression for the length of the temperature jump when using the temperature-jump method of obtaining the accommodation coefficients.

As regards polyatomic gases, here the coefficient K indicated in the table of results has a tendency to increase.

LITERATURE CITED

1. E. H. Kennard, Kinetic Theory of Gases, McGraw-Hill, New York (1938).
2. L. B. Thomas and R. C. Golike, "A comparative study of accommodation coefficients by the temperature-jump and low-pressure methods and thermal conductivities of He, Ne, and CO_2 ," J. Chem. Phys., 22, No. 2 (1954).
3. F. M. Devienne, Flow and Heat Transfer of Rarefied Gases [Russian translation], IL, Moscow (1962).